

AIR ASSISTED LANCES

SINGLE ORIFICE NOZZLES

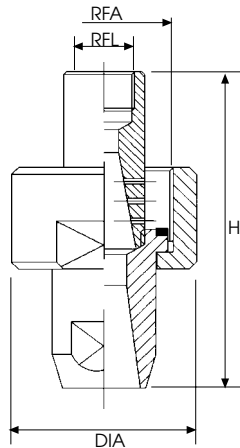

The air assisted lances of the NEB series work on the twin-fluid supersonic principle and provide a fine droplet spectrum. Air and liquid are mixed in the whirling chamber inside. The nozzle accelerates the mixture to supersonic velocity. These lances produces droplets with the following characteristics:

- Optimum particle distribution.
- Fine atomization.
- High exit velocity with an optimum particle exchange.

Materials

AISI 316 Stainless steel
Hastelloy C4

Code	D1	D	Liquid pressure (bar)									Dimensions				
			2,0			3,0			4,0			RFA	RFL	H	SW	
15°	NEB 1490 B3	3,0	4,2	1,8	0,6	37	2,7	0,8	48	3,6	0,9	62	1 1/4"	3/8"	83	50
				1,9	1,5	33	2,9	3,0	33	3,9	4,0	40				
				2,0	3,5	22	3,0	4,6	28	4,0	6,3	34				
	NEB 1740 B3	3,7	5,0	1,8	0,7	50	2,7	0,9	66	3,6	1,0	80				
				1,9	3,0	40	2,9	4,0	55	3,9	8,0	60				
				2,0	5,5	31	3,0	6,4	44	4,0	9,2	59				
	NEB 740 B3	2,0	5,5	1,5	1,0	58	2,2	1,2	76	3,2	1,2	95				
				1,8	5,0	52	2,6	7,0	69	3,6	10	83				
				2,0	10	48	3,0	14	60	4,0	19	73				
	NEB 2190 B3	2,8	7,6	1,5	1,2	95	2,2	1,5	124	3,1	1,8	155				
				1,7	7,0	90	2,5	10	112	3,5	15	140				
				2,0	18	71	3,0	19	100	4,0	23	136				
	NEB 2260 B3	3,2	9,5	1,4	1,2	155	2,2	1,5	200	3,0	1,8	250				
				1,7	10	130	2,6	15	170	3,5	20	200				
				2,0	25	102	3,0	26	145	4,0	32	187				

CODING FOR AIR ASSISTED LANCE

Assigning a code containing detailed product description is of utmost importance for customer service along the life time operation of the product.

Apart from some information typical for every specific installation, which are defined within the already mentioned 9E type form, our air assisted lances are coded according to the following scheme.

Where the code parameters carry the following meanings

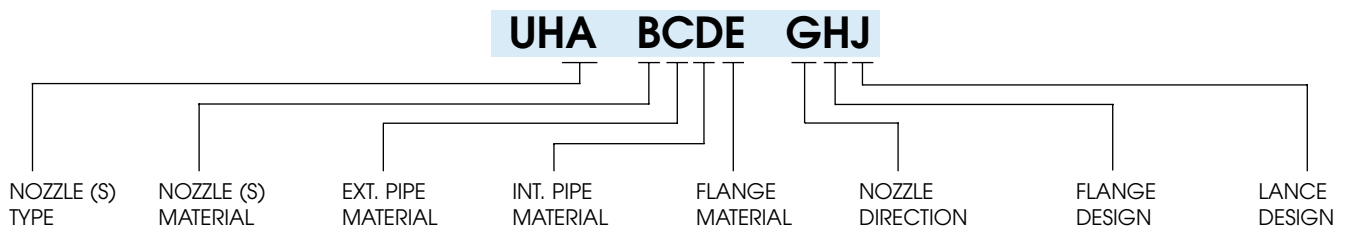

AIR ASSISTED LANCES

MULTI ORIFICE NOZZLES

The multi orifice nozzles of the NE series give the additional advantages of a wide operating liquid flow range, wider spray angles, assuring very fine spray characteristics. The typical design of these lances allows for the liquid feed nozzle to be easily replaced, and made out of wear resistant materials for those applications where solid particles suspended in the liquid would cause excessive erosion.

Materials

- Aisi 316 Stainless steel
- Hastelloy C276
- Hastelloy C22
- Hastelloy C4

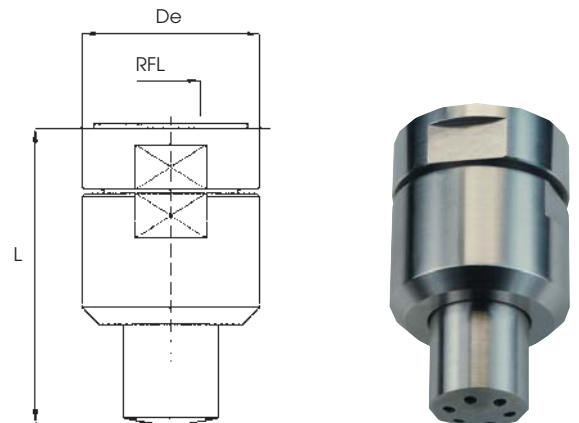

Code	Liquid pressure (bar)									Dimensions						
	3			4			5			L	De	RFL				
Code	LC	AC	LC	AC	LC	AC	LC	AC	LC	AC	L	De	RFL			
20°	NFC 2120	2,2	2	55	2,9	2	68	3,8	2	94	80	48,3	3/4"			
		2,8	6	40	3,6	6	52	4,4	6	75						
		3,3	9	30	4,2	9	42	5,3	9	62						
	NFC 2275	2,5	7	145	3,2	7	190	4,2	7	250				113	68,0	3/4"
		3,5	17	115	4,2	17	160	5,3	17	200						
		4,6	27	100	5,5	27	135	6,4	27	180						
	NFC 2340	2,6	15	150	3,2	15	185	4,2	15	230				113	68,0	3/4"
		3,3	34	100	4,2	34	125	5,2	34	170						
		4,3	50	70	5,2	50	100	6,1	50	135						
	NFC 2890	3,5	58	75	4,4	58	110	5,3	58	145				113	68,0	3/4"
		4,0	74	50	5	74	78	5,8	74	115						
		4,6	94	33	5,8	94	60	6,4	94	85						
50°	NFN 2120	2,2	2	55	2,9	2	68	3,8	2	94	80	48,3	3/4"			
		2,8	6	40	3,6	6	52	4,4	6	75						
		3,3	9	30	4,2	9	42	5,3	9	62						
	NFN 2275	2,5	7	145	3,2	7	190	4,2	7	250				113	68,0	3/4"
		3,5	17	115	4,2	17	160	5,3	17	200						
		4,6	27	100	5,5	27	135	6,4	27	180						
	NFN 2340	2,6	15	150	3,2	15	185	4,2	15	230				113	68,0	3/4"
		3,3	34	100	4,2	34	125	5,2	34	170						
		4,3	50	70	5,2	50	100	6,1	50	135						
	NFN 2890	3,5	58	75	4,4	58	110	5,3	58	145				113	68,0	3/4"
		4,0	74	50	5	74	78	5,8	74	115						
		4,6	94	33	5,8	94	60	6,4	94	85						

VALUES FOR CODING PARAMETERS

<p>A Nozzle type</p> <ul style="list-style-type: none"> A NEB 1490 B NEB 1740 C NEB 2140 D NEB 2190 E NEB 2260 G NFC 2120 H NFC 2275 K NFC 2340 L NFC 2890 M NFC 3150 O NFN 2120 P NFN 2275 Q NFN 2340 R NFN 2890 S NFN 3150 X Special 	<p>B Nozzle material</p> <ul style="list-style-type: none"> A AISI 316 L B Hastelloy C 276 C Hastelloy C 22 D Hastelloy C 4 E Other C External pipe material See nozzle material codes D Internal pipe material See nozzle material codes E Flange material See nozzle material codes G Nozzle direction L Nozzle in line M Nozzle 45° up N Nozzle 90° up 	<p>Y Nozzle 45° down</p> <p>Z Nozzle 90° down</p> <p>X Other</p> <p>H Flange design Connection flange design according to:</p> <ul style="list-style-type: none"> A ASA 10" 150# B 2550 NB flange BS4504 PN16 C Rectangular PNR standard D DIN DN 250 PN 16 X Other <p>J Lance design</p> <ul style="list-style-type: none"> A Adjustable simple lances A Nominal length 500 mm B Nominal length 1000 mm C Nominal length 1500 mm D Adjustable non standard length lance 	<p>F Lances with additional air cooling</p> <p>H Lances with additional water cooling</p> <p>K Lances with protection pipe</p> <p>N Lances with air cooling and protection pipe</p> <p>X Other lances</p>
---	--	---	--